

Front view AW9/12-R32-M

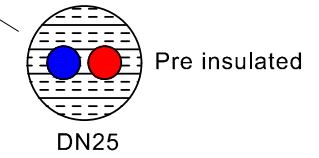

Side view AW9/12-R32-M

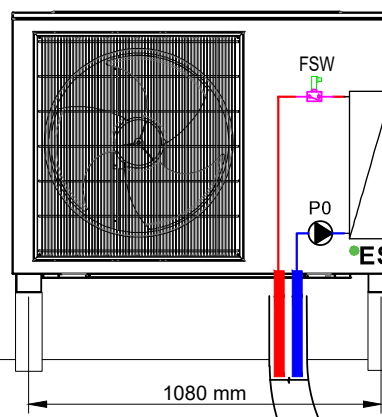
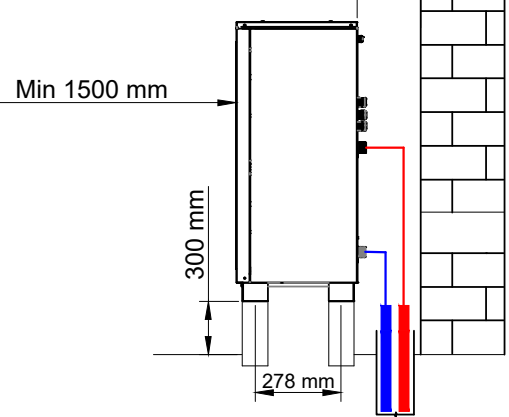

AWC6/19

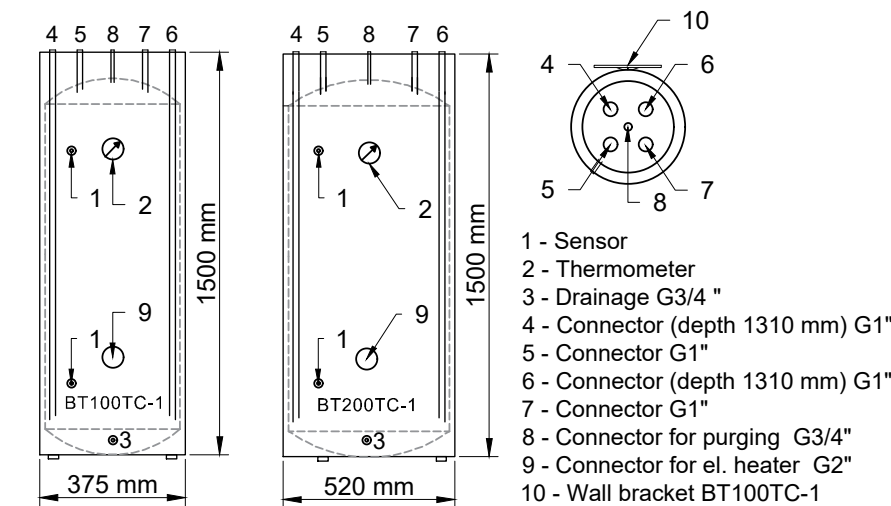
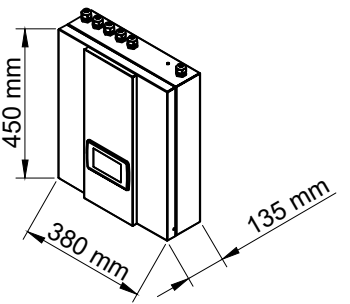

Classification of the Drawing/Klassifizierung/Klasifikacija risbe:		Date, Datum : 21.2.2020
	Title/Title: AWC9/12-R32-M, buffer BT100TC-1/200TC-1, 2 x mixing heating circuit, 2 x mixing heating / cooling circuit	Drawing ID/Zeichnungs ID/ Oznaka risbe: <b>Ver1</b>
	Naziv:	Revision/Prüfung/Revizija: MK