

• **EIS** ENERGY SAVE

LIGHT COMMERCIAL SYSTEMS

Reversible air source heat pump
for heating and cooling



ES Heat Pump Series for Commercial Applications

The ES heat pumps are powerful, yet simple solutions designed to meet heating, cooling, and domestic hot water demands for commercial buildings such as apartment complexes, hotels, schools, and warehouses. Their modular design allows for easy scalability, making them ideal for both small and large installations.

Advanced technology for reliability and performance

All ES heat pumps incorporate advanced features to ensure long-term reliability and efficiency:

- **Smart BEMS Integration:** Built-in Modbus communication allows seamless integration with building energy management systems (BEMS) for smart energy control.
- **Nano-Coated Outdoor Evaporator:** Reduces defrost times and minimizes ice buildup, ensuring consistent operation even in cold climates.
- **Modularity and scalability:** Units can be installed in cascaded systems, providing versatile and scalable heating solutions for commercial applications.

By offering both R290 and R410a options, the ES heat pump series provides a flexible, energy-efficient, and future-proof solution tailored to different commercial heating needs.



Two Refrigerant Options for Flexibility and Sustainability

The ES heat pump series is available with two different refrigerants: R290 and R410a, providing options for both performance optimization and environmental sustainability.

R290 series

Eco-friendly and efficient

The R290 model, available in 40 kW, is designed with sustainability in mind. As a low-GWP (Global Warming Potential) refrigerant, R290 provides a future-proof solution in line with evolving environmental regulations. It offers high efficiency while reducing environmental impact.

Key features of the R290 series:

- Natural refrigerant with ultra-low GWP, significantly reducing carbon footprint.
- Energy rating: A+++, making it one of the most efficient solutions available.
- COP of up to 4.6, ensuring stable and effective performance.
- Inverter-driven compressor for optimized energy use.
- Electronic expansion valve (EEV) for precision control.

R410a series

High performance and versatility

The R410a models are available in 45 kW, and 90 kW capacities.

Key features of the R410a series:

- EVI (Enhanced Vapor Injection) technology for increased efficiency and stable performance.
- Inverter-driven compressor for demand-based power adjustments, optimizing energy use.
- Energy rating: A++, with a COP of up to 4.5 for high energy efficiency.
- Monobloc design for simplified installation.
- Electronic expansion valve (EEV) for precise superheat regulation.

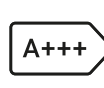

Scalability and Large-scale Applications

Both the R290 and R410a series can be connected in cascade configurations of up to 16 units, allowing a total capacity of up to 1,440/1,280 kW to be managed through a single controller. For even larger applications, multiple banks of cascaded systems can be integrated with several control units, enhancing system scalability and flexibility.

Indoor unit



ES NordFlex

R290 outdoor units



ES M40 R290

R410a outdoor units



ES AW90



ES AW45

Responsive Heat Pump Control

Enabling the Green Transition

The Nordflex control platform allows heat pumps to replace gas even in a challenging grid infrastructure. By dynamically adjusting output and working in concert with other energy sources, the system helps balance energy demand and reduce peak loads. This ensures that buildings can transition from fossil fuels to greener alternatives like electricity without waiting for extensive grid upgrades. With intelligent load management, heat pumps can provide reliable heating even when grid capacity is strained, accelerating the shift toward a more sustainable energy future.

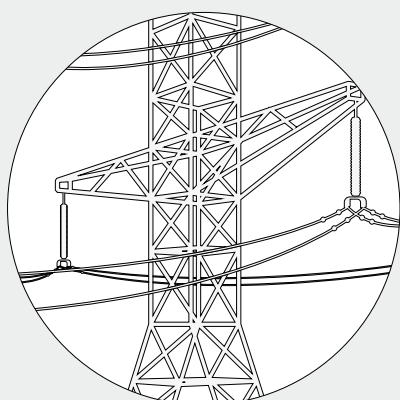

GRID

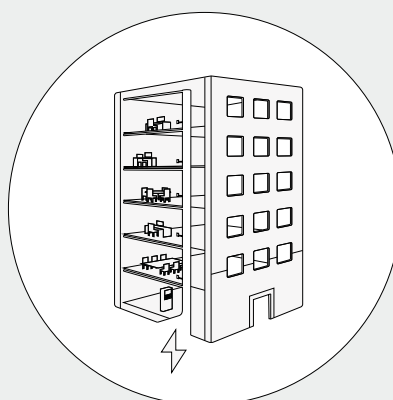

BEMS

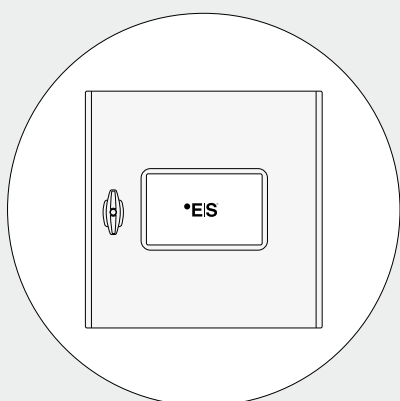

NORDFLEX

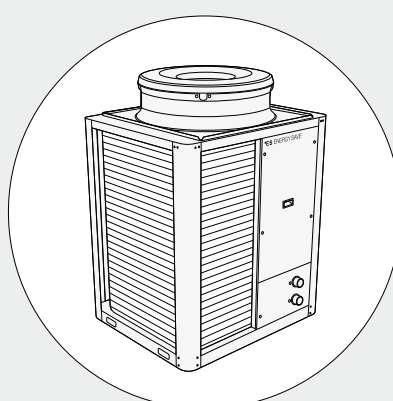

HEAT PUMPS

The System is Easily Monitored via the ES NordFlex Controller Display and ES Fleet Manager

A clear and user-friendly interface makes it easy to control and monitor your system(s) via the controller cabinet display and web application with our ES Fleet Manager platform. You can monitor both function and efficiency in real time and tailor the settings as needs change.

With the ES NordFlex controller and ES Fleet Manager, you can easily control and monitor your system via the controller display or remotely through the web application. A clear and user-friendly interface provides real-time insights into performance and efficiency, allowing you to tailor settings as needs evolve.



The ES NordFlex Controller Display

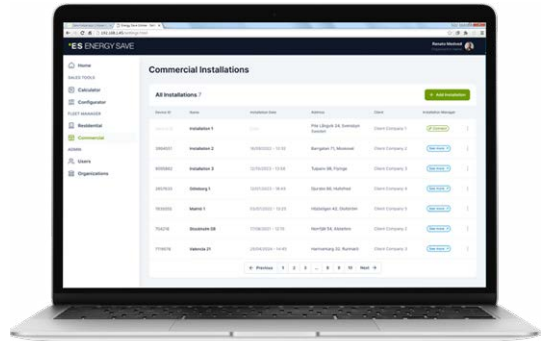

The ES Fleet Manager

Smart tools for easy calculation, sizing, and control

To simplify the design and management of your heat pump system, we offer a suite of intelligent tools:

- ES Configurator – Streamline system configuration and ensure optimal setup with ease.
- ES Calculator – Perform quick and accurate calculations for sizing and efficiency optimization.
- ES Fleet Manager – Gain full control over your system via a web-based platform for real-time monitoring and adjustments.

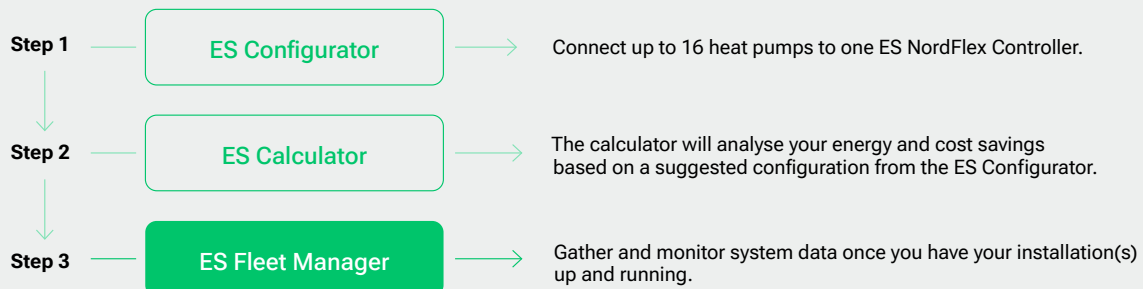

ES M40 R290

Performance Data

ES M40 R290

Min/max heating capacity (1)		kW	12.7/38.6
Min/max input power (1)		kW	2.8/12.3
COP min/max (1)		W/W	4.58/3.15
Min/max heating capacity (2)		kW	11.9/38.2
Min/max input power (2)		kW	3.3/12.8
COP min/max (2)		W/W	3.61/2.9
SCOP – Average climate (35°C/55°C)		W/W	4.6/3.5
Energy class – Heating (35°C/55°C)		–	A+++/A++
Min/max cooling capacity (3)		kWh	12,640/15,741
Min/max cooling capacity (3)		kW	12.1/34.2
Min/max input power (3)		kW	2.8/9.1
E.E.R min/max (3)		W/W	4.33/3.75
Min/max cooling capacity (4)		kW	4.5/25.1
Min/max input power (4)		kW	2.9/9.4
E.E.R min/max (4)		W/W	1.56/2.67
Ambient Temperature Range		°C	-25 to 43
Water temperature range (heating)		°C	70/20
Water temperature range (cooling)		°C	25/7
Sound power level, outdoor unit		dB(A)	62
Fan	Quantity		1
	Airflow	m³/h	12500
	Rated power	W	1100
Water side	Heat Exchanger Manufacturer		Danfoss
	Heat Exchanger Type		Plate Heat Exchanger
	Water Pressure Drop	kPa	85
	Piping Connection	Inch	G2"
Flow switch			Yes
Refrigerant	Type / Amount	- / kg	R290 / 4.2kg
Compressor	Type		Copeland Scroll
	Manufacturer		Copeland
Power supply		V/Hz/Ph	380/50/3
Net Dimension (LxDxH)	Indoor unit	mm	390x450x132
	Outdoor unit	mm	1,170x970x1,620
Net Weight	Indoor Unit	kg	10
	Outdoor Unit	kg	348
Article number	Outdoor Unit		120722
	Indoor Unit		120223

All data is subject to change without prior notice. We disclaim any liability for potential printing errors or inaccuracies.

(1) Heating conditions: water inlet/outlet temperature in/out: 35°C, Ambient temperature: 7°C. (2) Heating conditions: water inlet/outlet temperature in/ out: 45°C, Ambient temperature: 7°C. (3) Cooling conditions: water inlet/outlet temperature in/ out: 18°C, Ambient temperature: 35°C. (4) Cooling conditions: water inlet/outlet temperature in/ out: 7°C, Ambient temperature: 35°C.

ES M40 R290

Performance Graph

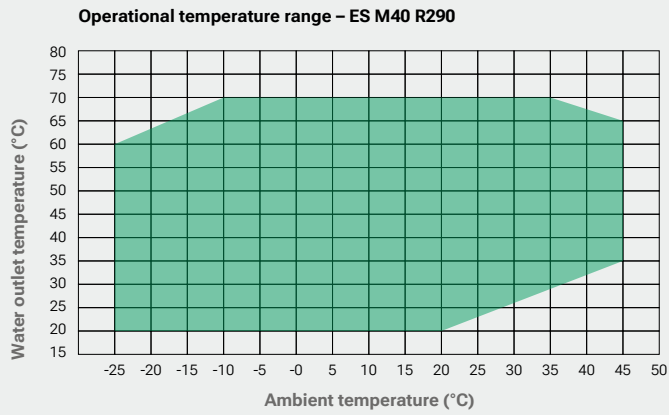
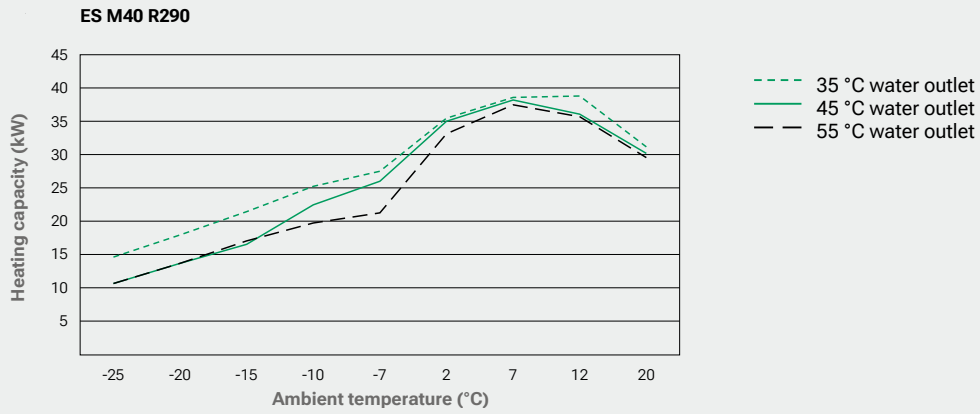

AW EVI-M

Performance Data

		AW 45-EVI-M		AW 90-EVI-M	
Min/max heating capacity (1)		kW	13.7–43.7		27.4–89.6
Min/max input power (1)		kW	3.3–12.1		6.7–24.3
COP min/max (1)		W/W	3.62–4.42		3.68–4.5
Min/max heating capacity (2)		kW	13.6–43.2		28.2–89.5
Min/max input power (2)		kW	4.2–14.3		8.2–28.3
COP min/max (2)		W/W	2.99–3.38		3.16–3.48
SCOP – Average climate, low temperature (1)		W	4.18		4.14
Energy class (1)			A++		A++
SCOP – Average climate, high temperature (6)		W	3.62		3.62
Energy class (6)			A++		A++
Min/max cooling capacity (3)		kW	17.7–32.0		36.4–66
Min/max input power (3)		kW	3.15–11.6		6.9–23.5
E.E.R min/max (3)			2.72–5.09		3.16–3.48
Min/Max cooling capacity (4)		kW	11.2–29.9		23.4–61.2
Min/Max input power (4)		kW	3.5–11.6		6.9–23.5
E.E.R min./max. (4)		W/W	2.6–3.3		2.6–3.4
Min/Max ambient working temperature in heating mode		°C	-30°–55°		-30°–55°
Min/Max ambient working temperature in cooling mode		°C	15°–55°		15°–55°
Max flow temperature in heating mode		°C	60°		60°
Min flow temperature in heating mode		°C	20°		20°
Min flow temperature in cooling mode		°C	7°		7°
Sound power level LwA – Average climate, low temperature (1)	Outdoor	dB (A)	71		74
Sound power level LwA – Average climate, high temperature (6)	Outdoor	dB (A)	72		75
Fan	Quantity	pcs	1		2
	Airflow	m ³ /h	13,500		13,500 x 2
	Rated power	W	800		800 x 2
	Blade diameter	mm	760		760 x 2
Plate heat exchanger	Water press. drop	kPa	80		100
	Pipe connection	inch	2" female		DN65 Flange
Refrigerant	Type		R410A		R410A
	Charge	kg	8		8 x 2
	GWP	Co ₂ /kg	2088		2088
	t CO ₂ Equiv		16.7		33.4
Compressor	Manufacturer		SIAM (5)		SIAM (5)
	Type		Inverter + EVI		Inverter + EVI
Power supply – Outdoor unit		V/Ph/Hz	400V/3N/50		400V/3N/50
Fuse Outdoor unit		A	3p/40A/C		2 x 3p/40A/C
Electrical compressor heater		W	30		30 x 2
Nominal water flow		m ³ /h	8		16
Hydraulic connections		inch	2" female		DN65 Flange
Flow switch			Yes		Yes
Net dimensions (L x D x H)	Outdoor unit	mm	1,010 x 1,158 x 1,645		2,158 x 1,158 x 1,645
	NordFlex	mm	400 x 400 x 200		400 x 400 x 200
Net weight	Outdoor unit	kg	330		682
	NordFlex	kg	12		12
Article number	Outdoor unit		120300		120307
	NordFlex		120223		120223

(1) Heating conditions: water inlet/outlet temperature in/out: 30°C/35°C, Ambient temperature: DB 7°C/WB 6°C (2) Heating conditions: water inlet/outlet temperature in/out: 40°C/45°C, Ambient temperature: DB 7°C/WB 6°C (3) Cooling conditions: water inlet/outlet temperature in/out: 23°C/18°C, Ambient temperature: DB 35°C/24°C (4) Cooling conditions: water inlet/outlet temperature in/out: 12°C/7°C, Ambient temperature: DB 35°C/24°C (5) A part of Mitsubishi Group (6) Heating conditions: water inlet/outlet temperature in/out: 50°C/55°C, Ambient temperature: DB 7°C/WB 6°C

AW EVI-M

Performance Graphs

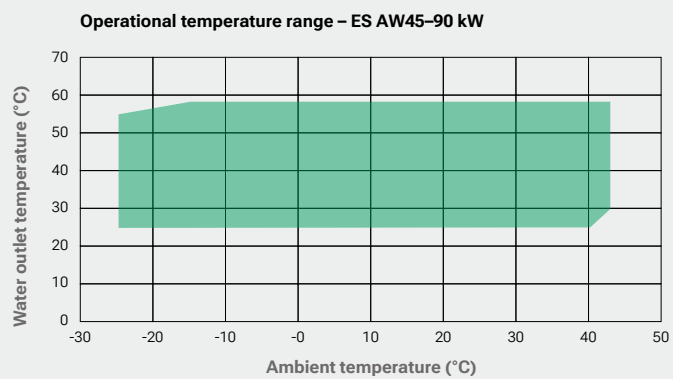
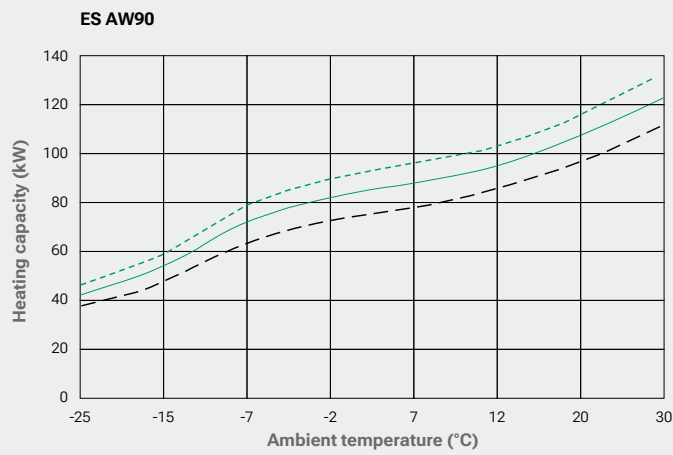
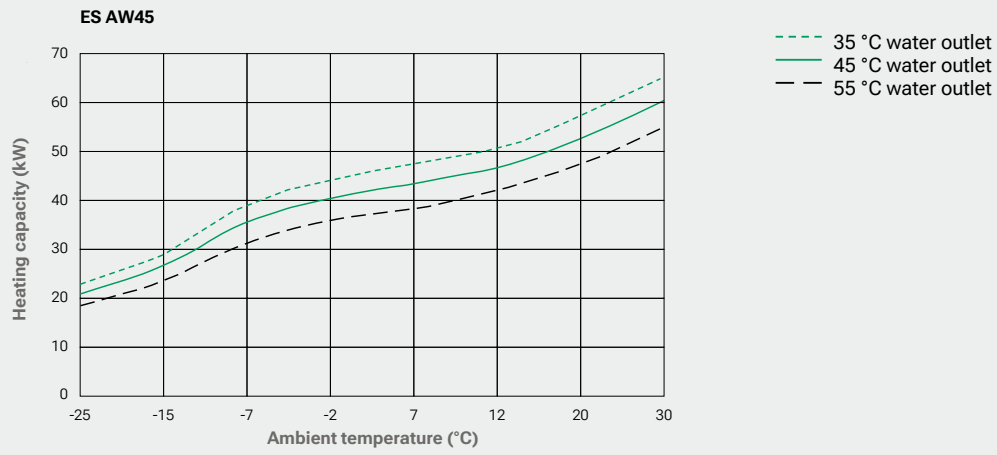

Controller Data

ES NordFlex	
Possible cascade heat pump control	16 (1.4 MW)
Possibility to connect multiple controllers	Yes
System configuration tool	Yes
Cascade control logic	Need based on heating/cooling demand – output based on the maximum COP output of each heat pump
Preprogramed system specific	Yes
Heat demand calculations	Calculated curve or laniary curve
Additional heater support	Yes – multiple
Additional heating sources control logic	On/Off; 0–10 V signal; Modbus communication
District heating connectivity	Yes
Domestic hot water production	Yes
Domestic hot water circulation control	Yes
Cooling production	Yes
Simultaneous production of Heat/DHW/Cooling	Yes all modes – Simultaneous Heating/ DHW/Cooling
Display	7” touch screen
Tailored system documentation	Yes – Tailored system documentation
Scheduling functions	Holiday mode, Night mode, DHW Boost, Anti-legionella mode
Software update	Via USB or OTA
Settings and configurations	Installer menu & USB auto upload
Internet access	Yes – with LAN cable or modem
Possible user groups (zones)	4
Energy consumption meter	Yes – optional
Energy production meter	Yes – optional
Room sensor support	Multiple – based on demand
Pressure monitoring	Yes – Support for pressure switches and pressure measurement on primary and/or secondary water circuit
Input/output standard	12 Analog inputs (NTC or 0–10 V) 4 Digital inputs (230 V) 4 Digital inputs (24 V) 2 Analog outputs (0–10V) 14 Relays (2 A, 250 V)
Flexible function for inputs/outputs	Yes – functions dedicated to inputs/outputs by installer
Additional input/output	Yes – with input/output expansion module
Power supply to switching valves etc.	24V DC 40 VA included
Power supply	230 V
Communication	Modbus RTU/TCP
Specific hydraulic and electric scheme included	Yes – project specific with configurator
BEMS compatibility	Yes
Article number	120233

Want to Know More?

We can help you take control of your property's climate and choose the right energy solution that meets your needs and challenges. Energy Save can assist you when it comes to optimizing your building energy systems to maintain or obtain an environmental certification and of course reduce both consumption and cost. You can also contact your local supplier directly among our distribution and installation partners.

Our energy efficient solutions are suitable for:

Existing properties, new production and all kinds of temporary and mobile solutions including construction site heating and drying.

Contact us today if you would like to:

- Reduce your carbon footprint
- Reduce your energy costs
- Reduce investment costs
- Improve and take control of your indoor climate
- Invest in a sustainable energy solution

About Energy Save

ES Energy Save Holding AB (publ) is an innovative Swedish energy technology company that, through cost-effective and smart air-to-water heat pump systems, contributes to sustainable energy conversion in Europe. The company has been supplying heat pumps to the European market since 2009 and is listed on Nasdaq First North Growth Market.

Sweden, HQ

ES Energy Save Holding AB
Metallgatan 2-4, SE-441 32 Alingsås, Sweden

Norway

Energy Save AS
Kirkeveien 50, 1396 Hvalstad, Norway

Slovenia

Energy Save Nordic D.O.O.
Ulica heroja Nandeta 37, 2000 Maribor, Slovenia

www.energysave.se

Scan to access the
digital version of
this brochure



•EIS ENERGY SAVE